



# MDX-596

*Minidisc Recorder*

**OWNER'S MANUAL**

# CAUTION: READ THIS BEFORE OPERATING YOUR UNIT.

1. This unit is a sophisticated mini disc recorder. To ensure proper operation for the best possible performance, please read this manual carefully.
2. Install your unit in a cool, dry, clean place with good ventilation. Avoid placing it in direct sunlight, near sources of heat, or in locations subject to vibration, excessive dust, heat, cold, or moisture. To avoid humming sounds, position the unit away from other electrical appliances, motors, and transformers.
3. Do not operate the unit upside-down. It may overheat, possibly causing damage.
4. Do not place another component on top of this unit, to do so may discolor or damage the surface of the unit.
5. Do not open the cabinet of this unit, to do so may result in damage to the unit or electrical shock. If any foreign object or substance gets into the unit, contact your dealer for assistance.
6. When removing the power plug from the wall outlet, always pull directly on the plug; never pull the cord itself.
7. Do not apply excessive force when operating switches and knobs.
8. When moving the unit, be sure to first disconnect the power cord from the AC outlet and disconnect all cords connecting the unit to other equipment.
9. To prevent damage by lightning, disconnect the power cord from the wall outlet during an electrical storm.
10. Do not attempt to clean this unit with chemical solvents as this may damage the finish. Use a clean, dry cloth.
11. Be sure to read the "TROUBLESHOOTING" section for advice on common operating errors before concluding that your unit is faulty.
12. Keep this manual in a safe place for future reference.
13. The voltage to be used must be the same as that specified on this unit. Using this unit with a higher voltage than that which is specified is dangerous and may result in a fire or other type of accident causing damage. YAMAHA will not be held responsible for any damage resulting from use of this unit with a voltage other than that which is specified.

## Note

Please check the copyright laws in your country to record from records, compact discs, radio, etc. Recording of copyright material may infringe copyright laws.

CLASS 1 LASER PRODUCT  
LASER KLASSE 1 PRODUKT  
LUOKAN 1 LASERLAITE  
KLASS 1 LASER APPARAT

This mini disc recorder is classified as a CLASS 1 LASER product. The CLASS 1 LASER PRODUCT label is located on the rear exterior. (U.K., Europe and general models only)

## CAUTION FOR CARRYING THE UNIT

Before carrying the unit, first remove a disc from the unit, press POWER to turn the unit off, then disconnect the AC power plug from the wall outlet.

## WARNING

To reduce the risk of fire or electric shock, do not expose this appliance to rain or moisture.

To avoid electrical shock, do not open the cabinet. Refer servicing to qualified personnel only.

## DANGER

Invisible laser radiation when open and interlock failed or defeated. Avoid direct exposure to beam.

## CAUTION

Use of controls or adjustments or performance of procedures other than those specified herein may result in hazardous radiation exposure.

## Voltage Selector <General model only>

The voltage selector on the rear panel of this unit must be set for your local main voltage BEFORE plugging into the AC power supply.

Voltages are 110/120/220/240 V AC, 50/60 Hz.

# INTRODUCTION

Thank you for purchasing this YAMAHA product. We hope it will give you many years of trouble-free enjoyment. For the best performance, read this manual carefully. It will guide you in operating your YAMAHA product.

## FEATURES

- **MINI DISC Digital Audio System**
- **Digital Optical Input (2)/Output**
- **Sampling Rate Converter**
- **Repeat Function**
- **EDIT Function**
- **Synchronized Recording**
- **Time Rescue Record Function**
- **Monaural Recording**
- **Fade-in and Fade-out Functions**
- **Timer Playback and Recording**

US and foreign patents licensed from Dolby Laboratories Licensing Corporation.

## CONTENTS

<b>PART DESCRIPTIONS</b> .....	<b>4</b>	<b>EDITING</b> .....	<b>17</b>
FRONT PANEL .....	4	ERASE .....	17
REMOTE CONTROL .....	5	Disc Erase .....	17
Remote Control Operation Range .....	5	Track Erase .....	18
Battery Installation .....	5	Part Erase .....	18
<b>CONNECTIONS</b> .....	<b>6</b>	Disc or Track Title Erase .....	19
ANALOG CONNECTIONS .....	6	MOVE .....	19
DIGITAL CONNECTIONS .....	6	COMBINE .....	20
<b>PLAYBACK</b> .....	<b>7</b>	DIVIDE .....	20
Skipping Tracks .....	7	UNDO .....	21
Searching .....	7	DISC MAINTENANCE .....	21
Switching the Display .....	8	TOC WRITE .....	21
RANDOM PLAY .....	9	FRA CHECK .....	21
REPEAT PLAY .....	9	<b>TITLING</b> .....	<b>22</b>
Single Track Repeat / Full Disc Repeat .....	9	<b>TIMER OPERATIONS</b> .....	<b>23</b>
Part (A-B) Repeat .....	10	Timer Recording .....	23
PROGRAM PLAY .....	10	Timer Playback .....	23
Using Headphones for Private Listening .....	11	<b>MD SYSTEM LIMITATIONS</b> .....	<b>24</b>
<b>RECORDING</b> .....	<b>12</b>	<b>DISPLAY MESSAGES</b> .....	<b>25</b>
Adjusting Recording Levels .....	13	<b>COPY PROTECTION (SCMS)</b> .....	<b>25</b>
Auto Marking .....	14	<b>TROUBLESHOOTING</b> .....	<b>26</b>
Using the Fade-in and Fade-out Functions .....	14	<b>SPECIFICATIONS</b> .....	<b>27</b>
TIME RESCUE RECORDING .....	15		
SYNCHRO RECORDING .....	15		
MONAURAL RECORDING .....	16		
MONITOR OUT .....	16		
PROTECTING A RECORDED MD .....	16		

# PART DESCRIPTIONS

## FRONT PANEL

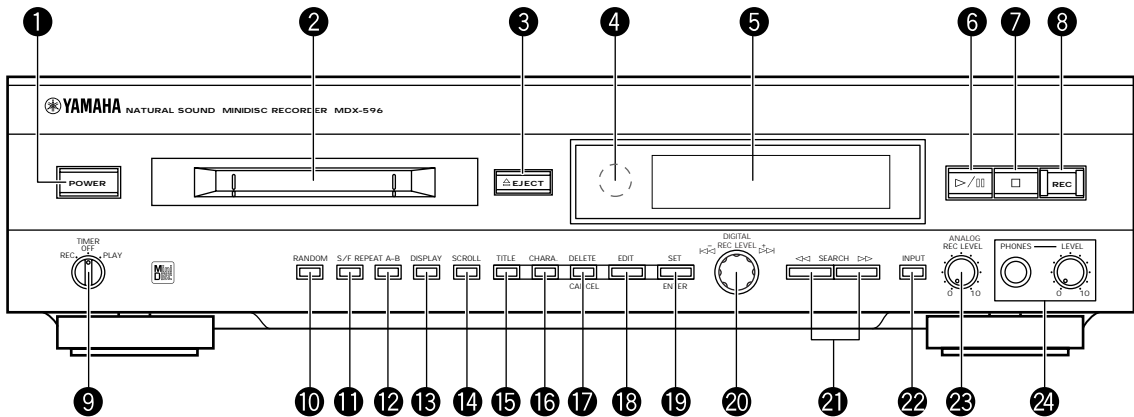

- |  |  |
|--|--|
| <p>① <b>POWER</b> (P.7)</p> <p>② Disc insertion slot (P.7)</p> <p>③ <b>EJECT</b> (P.7)</p> <p>④ Remote control sensor (P.5)</p> <p>⑤ Display</p> <p>⑥ ▷/⏏ (P.7)</p> <p>⑦ □ (P.7/P.13/P.17/P.22)</p> <p>⑧ <b>REC</b> (P.12~P.16)</p> <p>⑨ <b>TIMER</b> (P.23)</p> <p>⑩ <b>RANDOM</b> (P.9)</p> <p>⑪ <b>S/F – REPEAT</b> (P.9)</p> <p>⑫ <b>A-B – REPEAT</b> (P.10)</p> <p>⑬ <b>DISPLAY</b> (P.8)</p> | <p>⑭ <b>SCROLL</b> (P.8)</p> <p>⑮ <b>TITLE</b> (P.22)</p> <p>⑯ <b>CHARA.</b> (P.22)</p> <p>⑰ <b>DELETE/CANCEL</b> (P.17/P.22)</p> <p>⑱ <b>EDIT</b> (P.17~P.21)</p> <p>⑲ <b>SET/ENTER</b> (P.17~P.21)</p> <p>⑳ Jog dial (◀◀ ▶▶)/<b>DIGITAL REC LEVEL</b> (P.7/P.13/P.18~P.20/P.22)</p> <p>㉑ <b>SEARCH</b> ◀◀ ▶▶ (P.7/P.22)</p> <p>㉒ <b>INPUT</b> (P.12)</p> <p>㉓ <b>ANALOG REC LEVEL</b> (P.13)</p> <p>㉔ <b>PHONES</b> (P.11)<br/> <b>PHONES</b> jack<br/> <b>PHONES LEVEL</b> knob</p> |
|--|--|

## REMOTE CONTROL

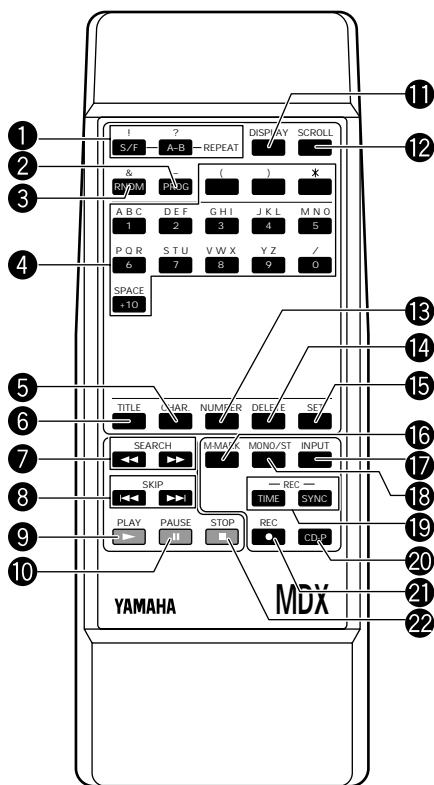

- |   |  |
|---|--|
| <p>① REPEAT (P.9/P.10)<br/>S/F [ ! ]<br/>A-B [ ? ]</p> <p>② PROG [ - ] (P.10/P.11)</p> <p>③ RNDM [ &amp; ] (P.9)</p> <p>④ Numbers [Characters] (P.7/P.22)</p> <p>⑤ CHAR. (P.22)</p> <p>⑥ TITLE (P.22)</p> <p>⑦ SEARCH &lt;&lt; &gt;&gt; (P.7/P.22)</p> <p>⑧ SKIP &lt;&lt;&lt; &gt;&gt;&gt; (P.7/P.22)</p> <p>⑨ PLAY ▷ (P.7/P.13)</p> <p>⑩ PAUSE ⏸ (P.7/P.13)</p> <p>⑪ DISPLAY (P.8)</p> | <p>⑫ SCROLL (P.8)</p> <p>⑬ NUMBER (P.22)</p> <p>⑭ DELETE (P.22)</p> <p>⑮ SET (P.22)</p> <p>⑯ M-MARK (P.14)</p> <p>⑰ INPUT (P.12)</p> <p>⑱ MONO/ST (P.16)</p> <p>⑲ Special Record buttons<br/>TIME (P.15)<br/>SYNC (P.15)</p> <p>⑳ CD-P (P.15)</p> <p>㉑ REC ○ (P.12~P.16)</p> <p>㉒ STOP □ (P.7/P.13/P.22)</p> |
|---|--|

### Remote Control Operation Range

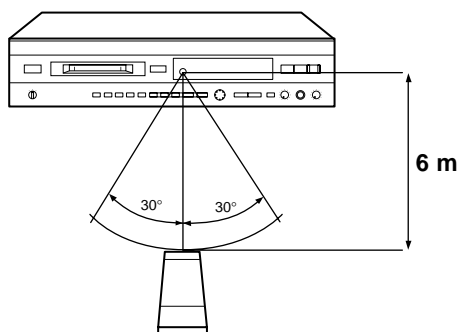

#### Notes

- There should be no large obstacles between the remote control and the remote sensor on the main unit.
- Strong light (especially from an inverter type fluorescent lamp) shining directly on the remote sensor may prevent proper operation. In such cases, reposition the main unit to avoid direct light.

### Battery Installation

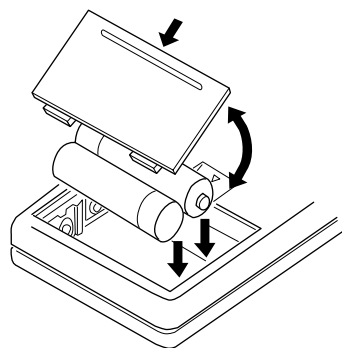

#### Battery replacement

When you notice a decrease in the operating range of the remote control, replace both batteries with new ones.

#### Notes

- Use only AA, R6, UM-3 batteries for replacement.
- Be sure to insert the batteries with correct polarity (as illustrated on the battery compartment).
- Remove the batteries if the remote control will not be used for an extended period of time.
- If batteries leak, dispose of them immediately. Avoid touching the leaking material or letting it come into contact with clothing, etc. Clean the battery compartment thoroughly before installing new batteries.

# CONNECTIONS

**Do not plug in this unit (or other components) until all connections are complete.**

- Connections should be made to the correct input/output terminals on the other component.
- Also refer to the owner's manual supplied with the component you are connecting.
- If the placement of this unit causes noise in other equipment, such as a tuner, move them farther apart.

## ANALOG CONNECTIONS

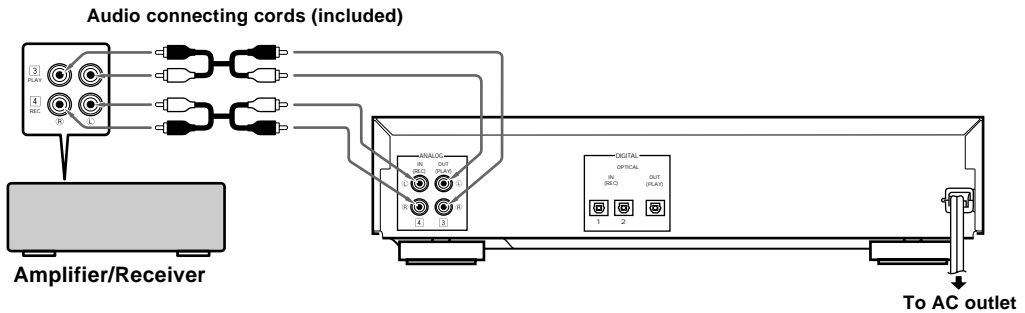

### Notes for analog connections

- The white plug on the audio connecting cords corresponds to the L (left) channel and the red plug corresponds to the R (right) channel. Be sure to connect L (left) to L and R (right) to R. Also make sure that the plugs are fully inserted and that the connection is firm.
- The ANALOG OUT jacks on the MD recorder should be connected to the MD PLAY jacks on your amplifier.
- The ANALOG IN jacks on the MD recorder should be connected to the MD REC jacks on your amplifier.
- The ANALOG OUT terminals on this unit are numbered 3 and the ANALOG IN jacks are numbered 4. When connecting this unit to a YAMAHA amplifier or receiver whose terminals are numbered 1, 2, 3, 4 ... (etc.), connect this unit's ANALOG OUT terminals to the input terminals numbered 3 and connect this unit's ANALOG IN terminals to the output terminals numbered 4 on the rear panel of the amplifier or receiver.

## DIGITAL CONNECTIONS

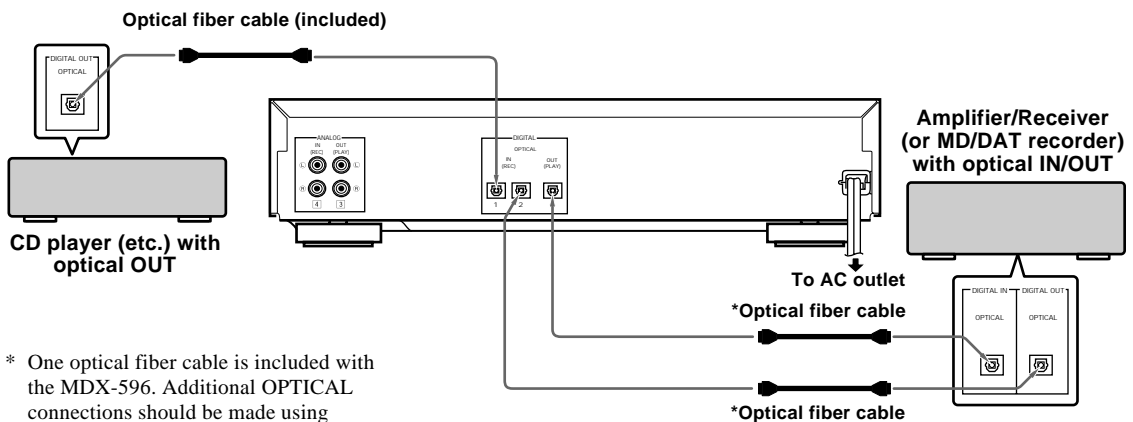

\* One optical fiber cable is included with the MDX-596. Additional OPTICAL connections should be made using commercially available optical fiber cables.

### Notes for digital connections

- The DIGITAL IN terminals can be connected to any component with an optical output so you can make direct digital recordings.
- The DIGITAL OUT terminal can be connected to a any component with an optical input so you can output digital audio from an MD.
- Before making OPTICAL connections, remove the terminal cover(s).
- In order to protect the terminals from dust, be sure to attach the terminal covers when the optical terminals are not being used.

# PLAYBACK

## Preparations

- Be sure to set the **TIMER** switch to OFF, then press **POWER** to turn this unit on.
- Set your amplifier or receiver to MD.

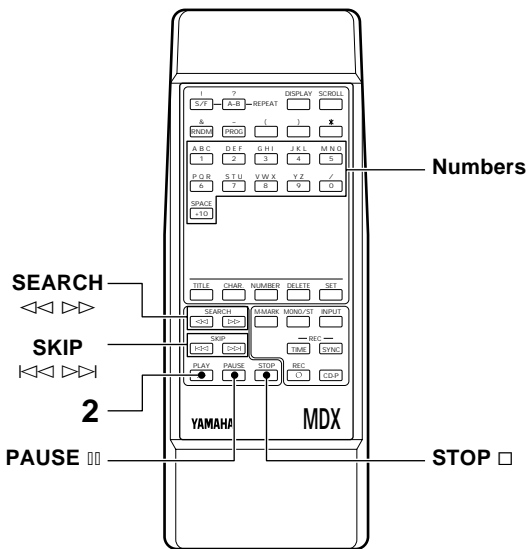
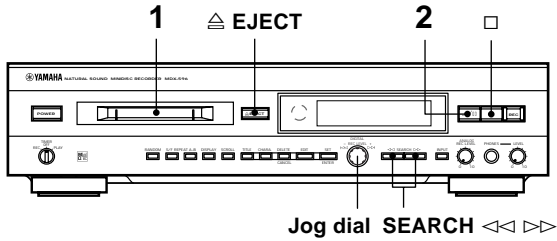

## 1 Insert an MD.

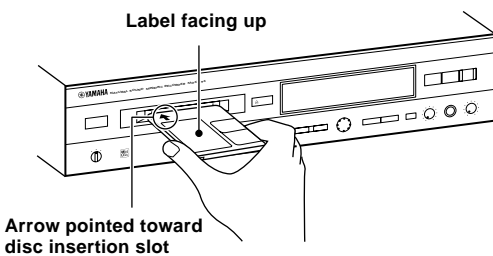

- 2 Press **▷/▶** (**PLAY ▷** on the remote) to start playback.
- 3 Adjust the volume using the volume control on your amplifier or receiver.

## To pause

Press **▷/|||** (**PAUSE |||** on the remote). Press again to resume playback (or press **PLAY ▷** on the remote).

## To stop

Press **□** (**STOP □** on the remote).

## To eject the MD

Press **△** **EJECT**.

## Note

The MONO indicator lights when playing monaural MDs.

## Skipping Tracks

### To skip to the next track

Turn the jog dial to the right (or press **SKIP ▷▶** on the remote).

### To skip to a previous track

Turn the jog dial to the left (or press **SKIP ◀◀** on the remote).

Turn one click to skip to the beginning of the current track. Turn an additional click to skip back to the beginning of each previous track.

### To skip to a specific track number

Press the number buttons on the remote corresponding to the track you desire.

#### Example:

To select track 3, press **3**.

To select track 13, press **+10**, then press **3**.

To select track 23, press **+10** twice, then press **3**.

### To skip to the last track on the disc

Turn the jog dial to the left when the display is showing the total tracks and total playing time.

## Searching

### To search forward during play or pause

Press and hold **SEARCH ▷▶**.

### To search in reverse during play or pause

Press and hold **SEARCH ◀◀**.

## Notes

- Sound can be heard when searching in play mode to help you locate the desired position within the track. No sound is heard when searching in pause mode, but the search is conducted at a higher speed.
- Search may not function correctly when there are several consecutive tracks consisting of only a few seconds each.

## Switching the Display

When you insert an MD, the disc title is displayed automatically.

Press **DISPLAY** during stop or playback to display other information, such as the remaining time and track titles.

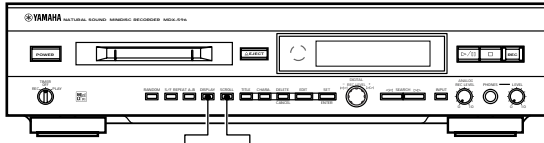

DISPLAY SCROLL

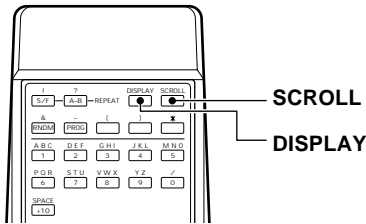

SCROLL

DISPLAY

### During stop

Press **DISPLAY** repeatedly to display the following information.

#### ① Number of tracks and total playing time

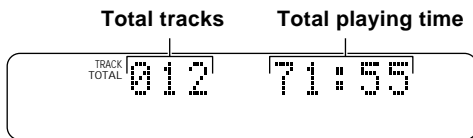

#### ② Time remaining on the MD (only for recordable MDs)

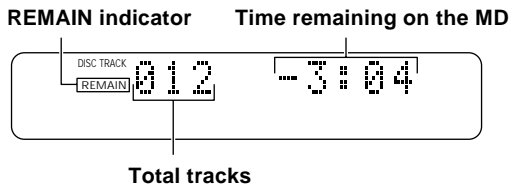

Total tracks

#### ③ Disc title

If the disc has not been given a name, "No Title" is displayed.



### During playback

Press **DISPLAY** repeatedly to display the following information.

#### ① Current track number and elapsed time

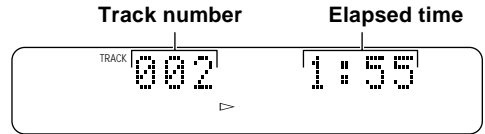

#### ② Time remaining on the current track

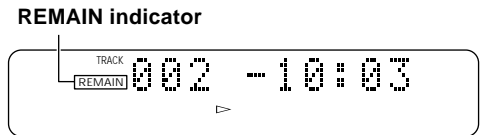

#### ③ Track title

If the track has not been given a name, "No Title" is displayed.



### To view the entire disc (track) title

If the disc (track) title is too long to fit in the display, press **SCROLL** to move the title sequentially across the display. While the title is being displayed, press **SCROLL** to pause the display, and again to continue presentation of the title. Press and hold **SCROLL** for rapid presentation of the title.



## RANDOM PLAY

You can have the unit play all the tracks on a disc in random order.

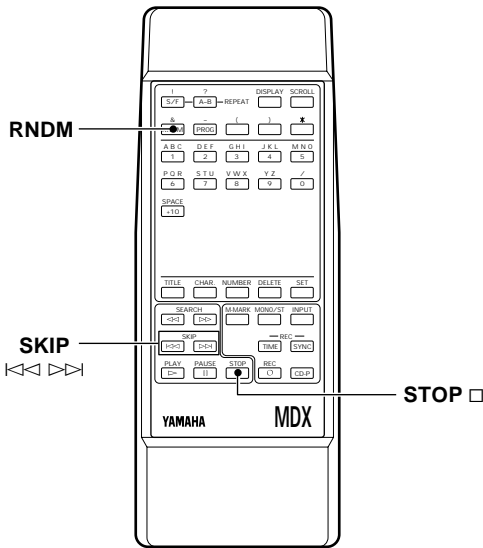
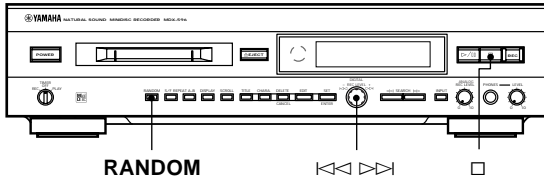

### To start random playback

Press **RANDOM (RNDM)** on the remote. The RANDOM indicator lights up and “\_ \_ \_ \_ \_ : \_ \_ \_” appears in the display while the unit selects a track. Playback starts automatically.

### To cancel

Press **STOP** on the remote) to stop playback. The RANDOM indicator turns off and random playback is canceled.

### Note

Pressing **SKIP** during random play skips to another track at random. Pressing **SKIP** returns to the beginning of the current track (you cannot return to previously played tracks).

## REPEAT PLAY

You can have the unit repeat a single track, a full disc, or just part of a track.

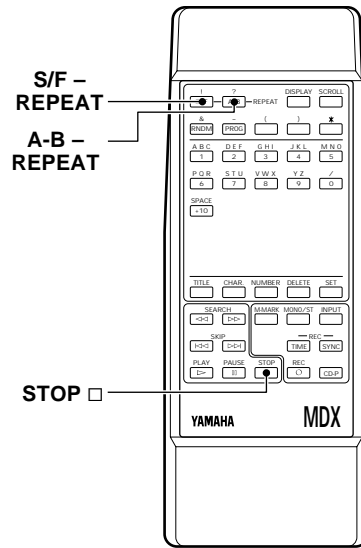
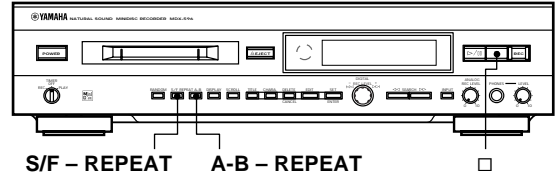

### Single Track Repeat / Full Disc Repeat

Press **S/F - REPEAT** repeatedly to light the REPEAT S or REPEAT F indicators.

To repeat the single track, light the REPEAT S indicators.



To repeat the full disc, light the REPEAT F indicators.



### To cancel

Press **S/F - REPEAT** repeatedly to turn off the REPEAT S or REPEAT F indicators.

### Notes on Full Disc Repeat

- In program play mode, the entire program is played repeatedly.
- In random play mode, the unit reshuffles the tracks and plays them again after each track plays once.

## Part (A-B) Repeat

This function lets you repeat a specific part of a track. It's a convenient way to study a language, or to learn the lyrics to your favorite song (etc.).

- 1 Press **A-B – REPEAT** during playback to specify the beginning (A point) of the part you want to repeat.

The REPEAT A indicators light up.



- 2 Press **A-B – REPEAT** again to specify the end (B point) of the part you want to repeat. The REPEAT A-B indicators light up and the part you specified starts to repeat.



### To cancel

Press  $\square$  or **A-B – REPEAT**.

## PROGRAM PLAY

This function lets you enjoy listening to your favorite tracks in any order you desire.

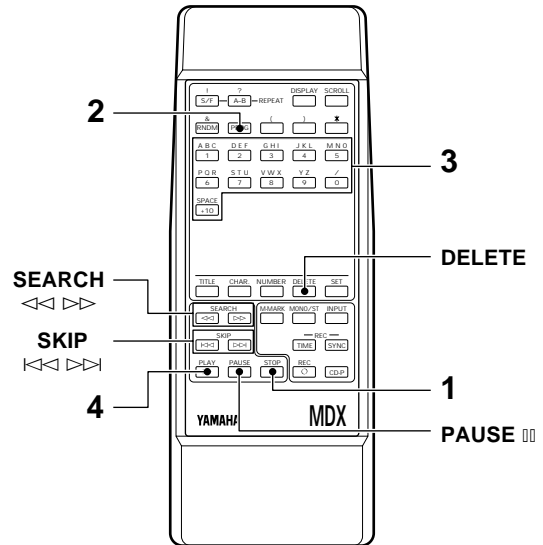

- 1 Press **STOP**  $\square$  to stop playback.
- 2 Press **PROG** to light up the PROGRAM indicator.
- 3 Program the desired track by pressing the corresponding number buttons.  
**Example:**  
To select track 3, press **3**.  
To select track 13, press **+10**, then press **3**.  
To select track 23, press **+10** twice, then press **3**.

The following display appears momentarily to show the step information:

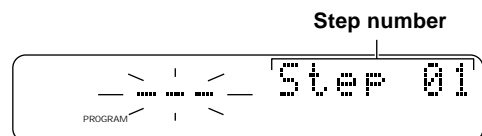

The display then switches to the program status:

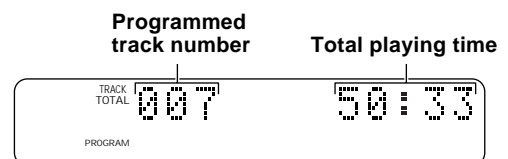

- 4 Repeat step 3 to program up to 30 steps.
- 5 Press **PLAY**  $\triangleright$  to start program playback.

### To check the programmed data

- ① Press **STOP**  $\square$  or **PAUSE**  $\square\square$  to stop or pause program playback.
- ② Press **SKIP**  $\lll$  or  $\ggg$  to skip through the step information (or use the jog dial on the front panel).

### To add a step

- ① Press **STOP**  $\square$  to stop program playback.
- ② Press **PROG** to enter the program input mode.
- ③ Press **SKIP**  $\ggg$  repeatedly until “\_” is displayed.
- ④ Use the number buttons to program a new track at the end of the program.

### To delete a specific step

- ① Press **STOP**  $\square$  to stop program playback.
- ② Press **PROG** to enter the program input mode.
- ③ Press **SKIP**  $\lll$  or  $\ggg$  to skip through the step information (or use the jog dial on the front panel).
- ④ Press **DELETE** (or **DELETE/CANCEL** on the front panel) to delete the step. The higher steps are renumbered automatically.

### To change a step

- ① Press **STOP**  $\square$  to stop program playback.
- ② Press **PROG** to enter the program input mode.
- ③ Press **SKIP**  $\lll$  or  $\ggg$  to skip through the step information (or use the jog dial on the front panel).
- ④ Use the number buttons to program a new track number for that step. The original track is cleared from memory and the new track is programmed.

### To cancel

Press **STOP**  $\square$  in the stop mode or the program input mode to turn off the PROGRAM indicator. The program is erased.

### Notes

- If the total time exceeds 255 minutes, “255mOver” is displayed instead of the total time.
- **SKIP**  $\lll$  or  $\ggg$  can be used during playback to skip between programmed tracks.
- **SEARCH**  $\ggg$  can be used during playback to search through all tracks in the current program.
- **SEARCH**  $\lll$  can be used during playback to return to the beginning of the current track.

## Using Headphones for Private Listening

---

Set the **PHONES LEVEL** knob on the front panel to “0” (minimum) and insert the headphones plug of your stereo headphones into the **PHONES** jack.

### To adjust the volume level of the headphones

Use the **PHONES LEVEL** knob.

Turn toward “10” (maximum) to increase the volume.

Turn toward “0” (minimum) to decrease the volume.

# RECORDING

This unit allows you to make recordings from a wide variety of program sources (both analog and digital). When recording an analog source (such as an FM broadcast or cassette) this unit converts the analog signals to a 44.1 kHz digital signal before recording them onto the MD.

When recording a digital source, this unit converts the digital signals to 44.1 kHz for recording onto the MD. However, if you are recording a 44.1 kHz source signal (such as a CD) there is no conversion. This unit can record 32, 44.1 and 48 kHz digital signals.

## Preparations

- Be sure to set the **TIMER** switch to OFF, then press **POWER** to turn this unit on.
- Set your amplifier or receiver to the program source to be recorded.

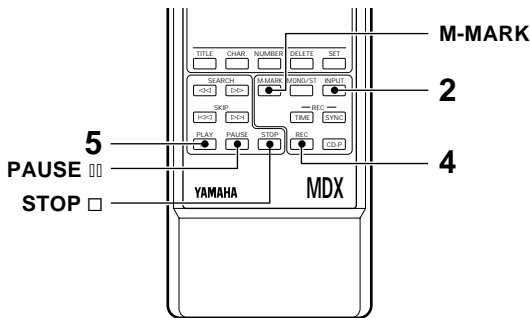
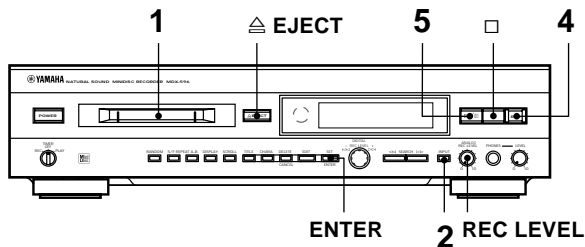

## 1 Insert an MD.

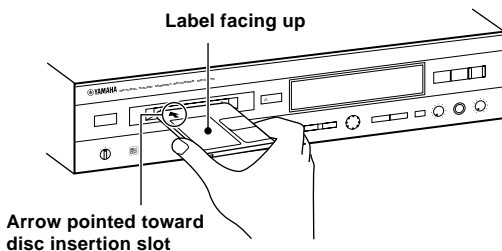

- 2 Press **INPUT** repeatedly to select the input connected to the sound source you want to record.

For	Select
LINE IN <span style="border: 1px solid black; padding: 0 2px;">4</span>	ANALOG
DIGITAL IN OPTICAL 1	DIGITAL OPT. 1
DIGITAL IN OPTICAL 2	DIGITAL OPT. 2

## Input indicator

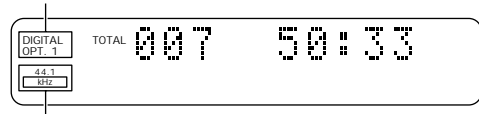

## (Source) sampling frequency indicators\*

\* Appears when digital signal is input.

- 3 Locate the point where you want to start recording.

- **When recording on a blank MD**  
Skip this step.
- **To start recording from the end of a previous recording**  
Press  $\square$  to set this unit to stop mode.
- **To record over a previous recording**  
Turn the jog dial (or press **SKIP**  $\lll$  or  $\ggg$  on the remote) to select a track (recording starts from the beginning of the deleted track), or press  $\triangleright/\square$  (**PAUSE**  $\square$  on the remote) during playback to pause at the point where you want to start recording.

- 4 Press **REC** (**REC**  $\circ$  on the remote) to set this unit to record pause mode.

The REC  $\square$  indicators light up. "REC Standby" and the amount of time available for recording flash alternately in the display.

## If you selected a track number or paused playback (in step 3) to record over a previous recording

"OverWrite OK?" appears in the display. To confirm, press **ENTER**. This operation will erase the selected track number (or point) and all subsequent material. To cancel, press **CANCEL** (or  $\square$ ).

## Adjust the recording level corresponding to the audio input you selected in step 2. Refer to "Adjusting Recording Levels" on page 13 for more details.

## Note

When recording from a digital source that has a digital output (volume) control, set the output level (volume) to "MAX". Recording may not be possible at low output levels (when the digital volume is turned down).

**5** Press  $\triangleright$ / $\square$  (**PLAY**  $\triangleright$  on the remote) to start recording.

The TOC indicator lights up.

When the TOC indicator is lit, this means that the TOC information has not yet been written to the disc. After recording is complete, the TOC data is automatically written to the disc.

**6** Start playing the program source to be recorded.

#### To pause

Press  $\triangleright$ / $\square$  (**PAUSE**  $\square$  on the remote).

Press again to resume recording.

#### To stop

Press  $\square$  (**STOP**  $\square$  on the remote).

#### To eject the MD

Press  $\triangle$  **EJECT**.

## Adjusting Recording Levels

### Setting the digital volume level

The volume level of digital audio sources is often similar, however, level differences may be quite obvious between different digital audio formats and even between one recording and another. To maintain a consistent volume level in MD recordings, it is possible to change the volume of the input digital signal.

To select the digital signal to be recorded or monitored, press **INPUT** repeatedly until the appropriate digital input indicator (DIGITAL OPT. 1 or DIGITAL OPT. 2) appears in the display. During record or record pause mode, turning **DIGITAL REC LEVEL** adjusts the volume of the digital signal. The digital volume can be adjusted up to +12 dB and down to a minimum (MIN) level from the default volume of 0 dB, the level of the input digital signal. To set the volume level, play the digital source to be recorded and adjust **DIGITAL REC LEVEL** so that the highest peak causes the 0 dB level indicators to flicker. The OVER indicators should not light.

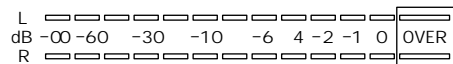

Should not light

Even when recording is stopped, the digital recording level is maintained in memory.

### Notes

- When **DIGITAL REC LEVEL** is turned, the digital volume level is adjusted in 0.5 dB steps between +12 dB and -20 dB, 1 dB steps from -20 dB to -30 dB, 2 dB steps from -30 dB to -40 dB, followed by -44 dB, -48 dB, -54 dB, -62 dB and MIN.
- Although some sources can be recorded with lower peak levels, setting the peak levels too low may degrade the quality of the recording.
- The digital volume cannot be adjusted while a track title is being entered.
- The digital recording levels are maintained independently for DIGITAL OPT. 1 and DIGITAL OPT. 2.

### Setting the analog recording level

Press **INPUT** repeatedly until the ANALOG indicator appears in the display, and press **REC** (**REC**  $\circ$  on the remote) to put this unit in the record pause or monitor out mode. For best results, play the loudest passage of the source to be recorded and watch the recording level meter in the display. Adjust **ANALOG REC LEVEL** so that the highest peak causes the 0 dB level indicators to flicker. The OVER segment should not light.

## Auto Marking

---

When making a recording, you can choose either automatic or manual marking. This feature operates somewhat differently for analog and digital signals. See below for details.

Press **M-MARK** on the remote repeatedly to select automatic (MANUAL indicator out) or manual (MANUAL indicator lit) marking.



### When recording analog signals

**Auto** : Track numbers are written in synchronization with the input level of the signal being recorded. During recording, if no sound is detected for more than 1.5 seconds, the recorder interprets this to be a gap between two tracks. When the source signal is detected again, a track number is automatically written.

**Manual** : One track number is written automatically when you start recording, but none are written during recording. To mark a track number, press **M-MARK** at the desired position while recording.

### Note

When using manual marking, the marks must be set at least 4 seconds apart.

### When recording digital signals

Track numbers are written in the same positions as the original source (CD, etc.) with either automatic or manual marking.

To add additional track numbers, set **M-MARK** to MANUAL and press **M-MARK** at the desired position while recording.

### Notes

- When recording is paused, the portion recorded up to the pause is counted as an individual track. When recording is resumed, a new track number is created.
- During synchronized recording, manual track marking is not possible.

## Using the Fade-in and Fade-out Functions

---

When making recordings, it is possible to fade-in at the beginning of a recording and fade-out at the end of a recording. This function is useful for custom recording of songs and other material.

### Fading in to a recording

Press **REC** (**REC** ○ on the remote) in step 5 of the recording procedure described on pages 12 and 13. “Fade in” is displayed and recording begins with a 10 second fade-in. (During the fade-in, the volume of the source being recorded is gradually increased to the set recording level.)

### Fading out of a recording



Press **REC** (**REC** ○ on the remote) while making a recording.

“Fade out” is displayed and a 10 second fade-out is performed. Following the fade-out, this unit is set to the record pause mode. (During the fade-out, the volume of the source being recorded is gradually decreased to the minimum level.)

## TIME RESCUE RECORDING

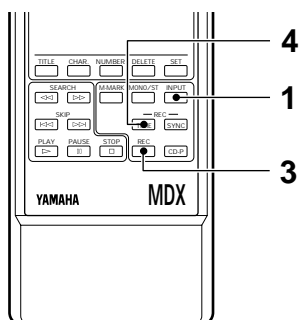
The Time Rescue (**TIME**) recording function allows you to start recording six seconds before you press record. During record pause mode, the MD recorder monitors the input signal and continuously maintains a six second memory “cache”. Therefore, you can record a song that just started without cutting off the beginning. You may find this function useful when recording live broadcasts, or when you want to start recording from the beginning of a song without recording lots of commercials (etc.).





- 1 Press **INPUT** repeatedly to select the input connected to the sound source you want to record.
- 2 Locate the point where you want to start recording.
- 3 Press **REC**  to set this unit to record pause mode.  
The REC  indicators light up.  
“REC Standby” and the amount of time available for recording flash alternately in the display.  
To adjust the recording level of digital or analog input sources, see “Adjusting Recording Levels” on page 13.
- 4 Press **TIME** to start recording when you hear the beginning of a song you want to record.  
Recording starts from the memory cache, allowing you to record from a point approximately six seconds before you pressed **TIME**.

## SYNCHRO RECORDING

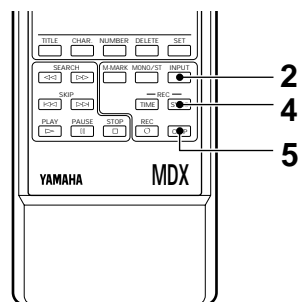
The synchronized recording function lets you set this unit to start recording automatically when a sound signal is input. When operating this unit in combination with a remote controllable Yamaha CD player, you can use the **CD-P** button on this unit’s remote control to start playback from the CD player.



- 1 Load the sound source into the source component.  
If necessary, program, or select the track you want to start recording from before proceeding to the next step. (Refer to the operation manual supplied with the source component for instructions regarding its use.)
- 2 Press **INPUT** repeatedly to select the input connected to the sound source you want to record.
- 3 Locate the point where you want to start recording.
- 4 Press **SYNC** to set this unit to record pause mode.  
The REC  indicators light up.  
“Synchro REC” and the amount of time available for recording flash alternately in the display.  
During synchronized recording, input sources are recorded at the current **ANALOG** and **DIGITAL REC LEVEL** setting.
- 5 Start playing the sound source. (Press **CD-P** if recording from a Yamaha CD player.)  
The MD starts recording automatically when a sound signal is input. When the sound signal stops, the unit switches back to record pause mode and “Synchro REC” blinks in the display.
- 6 To continue recording, repeat step 5.  
When you have finished recording, press  on this unit to cancel the record pause mode.

### Note

When the signals at the beginning of a track are lower than the level required to start synchronized recording, they are not recorded. Should this occur, perform manual recording.

## MONAURAL RECORDING

Recording in monaural (mono) allows you to record up to 148 minutes of sound on one 74 minute MD. (When recording in stereo you can record up to 74 minutes of sound.) This may be useful when recording an interview, debate, or whenever you want to record for a long time on one disc.

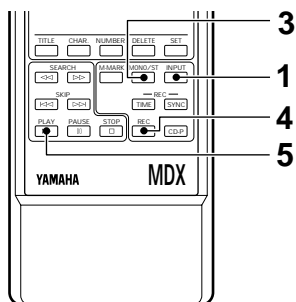

Press **MONO/ST** to light the MONO indicator after step 3 of the recording procedure described on pages 12 and 13.

## MONITOR OUT

When a disc is not loaded, you can use the monitor out function to monitor the sound of the input source. This allows you to enjoy better sound from your other digital source components, such as CD, by using this unit as a digital to analog converter.

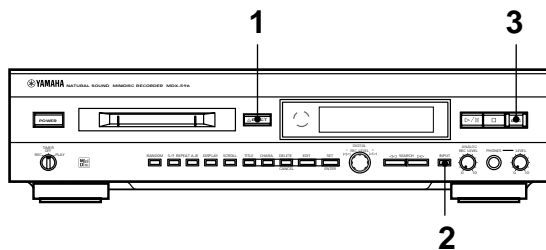

- 1 Press **EJECT** to remove the disc.
- 2 Press **INPUT** repeatedly to select the input connected to the sound source you want to monitor.
- 3 Press **REC**.  
“MONITOR OUT” appears in the display.  
Sound from the selected input will be output from this unit’s analog and digital output terminals.
- 4 Start playing the sound source selected in step 2.  
The sound is output from the MD recorder’s analog and digital output terminals.

### To cancel

Press **REC** again, press **□**, or insert a disc.

### Note

The digital volume can be adjusted when using the monitor out function.

## PROTECTING A RECORDED MD

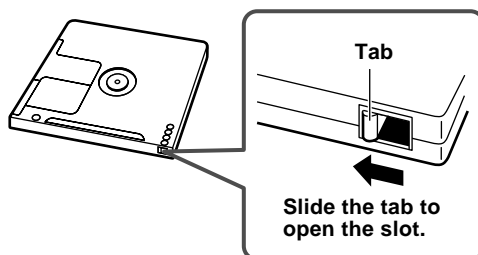

- To protect a recorded MD, slide the tab on the side of the MD to open the slot.  
In this position, the MD cannot be used for recording, editing, or titling. To record, edit, or title the MD, slide the tab to close the slot.
- If the MD is protected against erasure, “Protected” appears in the display.



One of the main advantages of MD is its editing capabilities. You can remove the commercials from a radio broadcast, reorder songs into the order you want, remove songs, combine songs, and even remove part of a song.

This unit offers the following editing operations.

(Please note that track numbers are updated automatically when you perform a ERASE, MOVE, COMBINE or DIVIDE operation.)

- **ERASE** (P.17~P.19)  
Lets you erase a track, the entire disc, or part of a track. You can also erase the title of a disc, or the titles of tracks on a disc.
- **MOVE** (P.19)  
Lets you move a track to a different track number.
- **COMBINE** (P.20)  
Lets you combine two adjacent tracks.
- **DIVIDE** (P.20)  
Lets you split a single track into two different tracks.
- **TOC WRITE** (P.21)  
Lets you write TOC information to the disc so that changes are saved.
- **FRA CHECK** (P.21)  
Lets you recover disc space that may have been lost after multiple edit operations.
- **UNDO** (P.21)  
Lets you undo the previous edit operation if you make a mistake (you cannot, however, undo the **UNDO** function).

## Notes on editing

- **To cancel an edit**  
Press **CANCEL** (or □).
- **Before editing**  
Make sure that the MD is not protected against erasure. If the MD is protected, you cannot edit the MD. Slide the tab to close the slot on the side of the MD.
- **After editing**  
Update the TOC information by pressing **EJECT** or using **TOC WRITE** function.

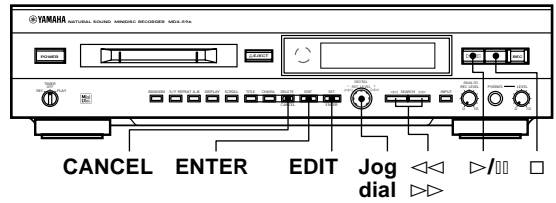

## ERASE

The ability to erase sound without having to re-record is a convenient function of MD. You can erase the entire disc, a single track, or just part of a track.

### Disc Erase

This operation lets you erase all audio and title (character) data to create a blank MD. Please note that once erased, this data can be recovered using the **UNDO** function.

- 1 Press **□** to set this unit to stop mode.
- 2 Press **EDIT** repeatedly to display “Disc Erase?”, then press **ENTER**.  
“Disc Erase OK?” appears in the display.
- 3 Press **ENTER** again.  
When all audio, name and title data has been erased “Complete” appears momentarily.

Continued on next page

## Track Erase

This operation lets you erase a single track as well as corresponding title data. After you erase the track, the total number of tracks decreases by one and all tracks following that track are renumbered.

### Example: Erasing track 3

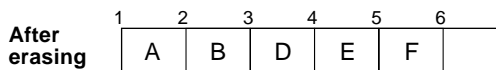
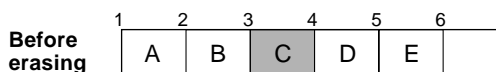

- 1 Turn the jog dial to select the track you want to erase.
- 2 Press **EDIT** repeatedly to display “Erase ?”, then press **ENTER**.  
“(track number) Erase OK?” appears in the display.
- 3 Press **ENTER** again.  
The track is erased and “Complete” appears momentarily.

### If you plan to erase two or more tracks

To avoid confusion you should always erase from higher track numbers to lower track numbers. This prevents accidental renumbering of tracks you plan to erase.

## Part Erase

This operation lets you erase part of a track.

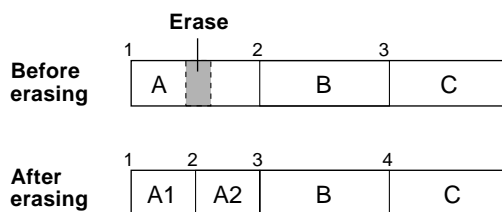

- 1 Play the track containing the part you want to erase.
- 2 Use **SEARCH** << or >> to locate the beginning of the part you want to erase (point A), then press >/ to pause at that point.
- 3 Press **EDIT** repeatedly to display “A-B Erase?”, then press **ENTER**.  
Point A (from step 2) is registered and “Erase A-” appears in the display.
- 4 Use >/ and **SEARCH** >> to locate the end of the part you want to erase (point B).
- 5 Press **ENTER** to register point B.  
“Check” appears momentarily in the display, and two second segments of the track immediately before point A and after point B play repeatedly. “Erase A-B?” appears in the display.  
**To adjust points A and B**  
Pressing **EDIT** repeatedly displays “← A Point →” and “← B Point →” alternately. Adjust the selected point by turning the jog dial in the direction you want to move the point.  
Each point can be adjusted up to 2 seconds (176 steps) in either direction.
- 6 Press **ENTER** again.  
The part is erased and “Complete” appears momentarily.

### To erase parts spanning more than one track

Use the **COMBINE** function described next to combine the tracks into one track before performing this operation.

### Notes

- After part erase, a new track number is automatically assigned to the section starting after point B.
- Point B cannot be positioned before point A.

## Disc or Track Title Erase

This operation lets you erase the title of the disc or the title of tracks on a disc. The title of the disc can only be erased during the stop mode, however, the title of the track can be erased during play or stop mode. In the stop mode, use the jog dial to select the track.

### To erase a disc title

- 1 Press  $\square$  to set this unit to stop mode.
- 2 Press **EDIT** repeatedly to display "Title Erase?", then press **ENTER**.  
"Disc Title" and "Erase OK?" appear alternatively in the display.
- 3 Press **ENTER** again.  
The disc title is erased and "Complete" appears momentarily.

### To erase a track title

- 1 Turn the jog dial to select the track with the title you want to erase.
- 2 Press **EDIT** repeatedly to display "Title Erase?", then press **ENTER**.  
"Track Title" and "Erase OK?" appear alternatively in the display.
- 3 Press **ENTER** again.  
The track title is erased and "Complete" appears momentarily.

### Notes

- Note that the DISC and TRACK indicators appear in the display when "Title Erase" is displayed to distinguish between the two operations.
- To avoid mistakes when erasing the disc or track names, press **DISPLAY** repeatedly until the title display screen appears so that titles can be confirmed beforehand.

## MOVE

This function lets you change the position of any track. When you move tracks, all tracks are automatically renumbered.

### Example: Moving track 2 to the track number 4

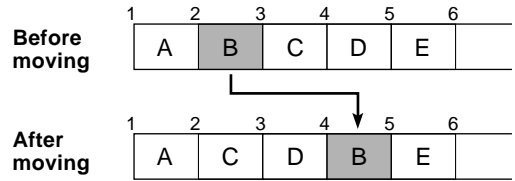

- 1 Turn the jog dial to select the track you want to move.
- 2 Press **EDIT** repeatedly to display "Move ?", then press **ENTER**.
- 3 Turn the jog dial to select the track's destination (new track number).

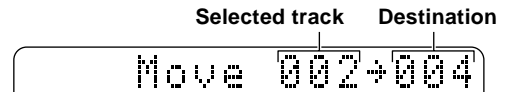

- 4 Press **ENTER**.  
"Complete" appears momentarily in the display.

## COMBINE

This function lets you combine two consecutive tracks into one. After you combine the tracks, the total number of tracks decreases by one and the tracks following the combined tracks are renumbered.

### Example: Combining tracks 2 and 3

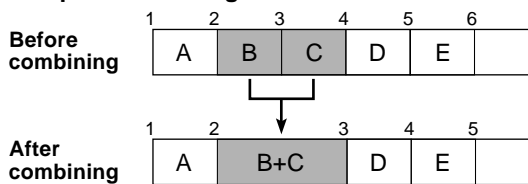

- 1 Press  $\square$  to stop playback.
- 2 Turn the jog dial to select the second track of the two you want to combine.
- 3 Press **EDIT** repeatedly to display “Combine ?”, then press **ENTER**.  
“Check” appears momentarily, then the MD recorder plays the 4 seconds before and after the point where the tracks will be connected. “(track number) + (track number) OK?” appears in the display.
- 4 Press **ENTER** again.  
The tracks are combined and “Complete” appears momentarily.

### Notes

- This operation is not possible when track 1 is selected.
- You can also divide the track later using the **DIVIDE** function.
- If “Can’t Edit” appears in the display, the tracks cannot be combined. This sometimes happens when you have edited the same track many times. This is due to the technical limitations of the MD system and is neither a mechanical error nor a malfunction.

## DIVIDE

This function lets you divide one track into two separate tracks by adding a new track number to a specified point in the track.

### Example: Dividing track 3

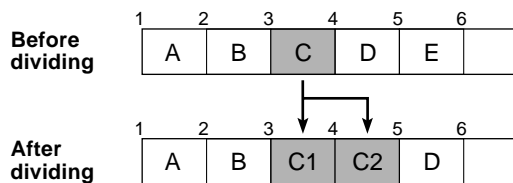

- 1 Play the track you want to divide.
- 2 Use **SEARCH**  $\lll$  or  $\ggg$  to locate the point where you want to divide the track, then press  $\triangleright/\square$  to pause at that position.
- 3 Press **EDIT** repeatedly to display “Divide ?”, then press **ENTER**.  
“Check” appears momentarily, then “Divide OK ?” appears and the MD recorder starts repeating the point where the track will be divided.
- 4 If necessary, use the jog dial to adjust the position of the point where the track will be divided.  
The dividing position can be adjusted up to 2 second (255 steps) in either direction.
- 5 Press **ENTER**.  
The track is divided and “Complete” appears momentarily.

### Note

You can also combine the tracks later using the **COMBINE** function.

## UNDO

The UNDO function lets you immediately return to the condition before an edit is made (note: you cannot undo an edit once you press any other button).

- ① Press  $\square$  to stop the MD recorder.
- ② Press **EDIT** repeatedly to display “Undo \_\_\_\_”, then press **ENTER**.  
“Undo OK ?” appears in the display. To cancel undoing, press **CANCEL** (or  $\square$ ).  
—<sup>1</sup>: The name of editing you can undo is displayed here.
- ③ Press **ENTER** again to undo.

### Notes

- You cannot undo an edit once it has been written to the TOC.
- The TOC indicator lights to show that the TOC information has not yet been written to the disc. Undo is possible only when the TOC indicator is lit. However, if you perform a recording operation (by pressing **REC**, **TIME**, or **SYNC**), **UNDO** is not possible even if the TOC indicator is lit.

## DISC MAINTENANCE

This unit features two disc maintenance functions which optimize performance of your MD discs. The TOC WRITE function allows you to write any edits to the TOC without having to eject the disc. The FRA CHECK function recovers recordable space on a disc that may have been lost because of multiple edit operations.

### TOC WRITE

When making a recording, the TOC (Table Of Contents) of the MD is written as soon as recording is finished. When making disc edits or titling, however, the TOC isn't automatically written unless the disc is ejected. If the unit is accidentally turned off before writing edits or titling to the TOC, it is possible that these changes will not be saved. By using this function, you can ensure that your edits or titles are saved on the disc.

- 1 Press  $\square$  to stop playback.
- 2 Press **EDIT** repeatedly to display “TOC Write ?”, then press **ENTER**.  
“TOC Write OK ?” appears.
- 3 Press **ENTER**.  
“TOC Writing” blinks in the display momentarily.

### Notes

- The TOC Write function can only be selected when the TOC indicator is lit in the display.
- You can update the TOC information by pressing  $\triangle$  **EJECT**.

When “TOC Writing” appears in the display, the TOC is being updated and edits are being written to the MD. While this message appears, do not pull the power plug from the wall outlet or subject the unit to shock or vibration.

### FRA CHECK

When edit functions such as “MOVE” and “DIVIDE” are performed, spaces of recordable space may be lost and “TOC Full” may appear in the display to indicate that no more recording can be performed. When this occurs, it may be possible to recover the FRA (Freely Recordable Area) on the disc that was lost during edit functions so that more recording is possible.

- 1 Press  $\square$  to stop playback.
- 2 Press **EDIT** repeatedly to display “FRA Check ?”, then press **ENTER**.  
“FRA Check OK ?” appears.
- 3 Press **ENTER**.  
“Complete” appears momentarily.

This function lets you title recorded MDs and the individual tracks. Titles may consist of uppercase and lowercase letters, numbers, and symbols for a maximum of up to 250 characters for each title.

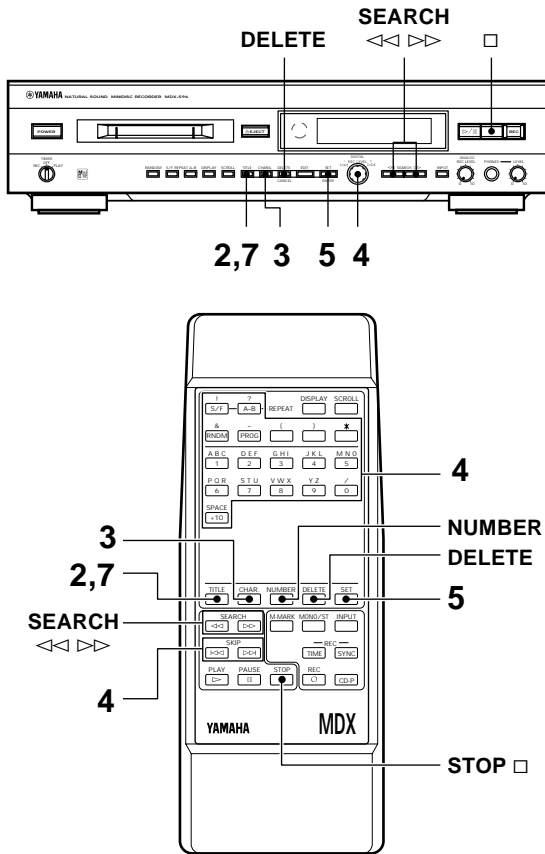

## 1 To title a disc

Press **□** (STOP **□** on the remote) to stop playback.

### To title a track

#### • During stop mode

Use the jog dial (SKIP **◀◀** or **▶▶** on the remote) to select the track you want to title.

#### • During playback or pause

Use the jog dial (SKIP **◀◀** or **▶▶** on the remote) to select the track you want to title, or go directly to step 2 to title the current track.

During playback, the unit automatically repeats the selected track while you are entering the title.

#### • During recording

Go directly to step 2 to title the current track.

Recording continues normally while you are entering the title for the selected track.

## 2 Press TITLE to activate the title mode.

The cursor appears in the display.

## 3 Using the front panel

Press **CHARA.** repeatedly to select between uppercase letters (“Char = ABC”), lowercase letters (“Char = abc”), and numbers (“Char = 012”).

**Note :** To access the symbols, select “A”, then turn the jog dial to the left.

### Using the remote

Press **CHAR.** repeatedly to select between uppercase letters (A) and lowercase letters (a).

## 4 Use the jog dial (the character buttons or SKIP **◀◀** or **▶▶** on the remote) to select a character, number, or symbol.

### Example (using the remote):

To select “A”, press **1 [ABC]** once.

To select “B”, press **1 [ABC]** twice.

To select “C”, press **1 [ABC]** three times.

To select “1”, press **NUMBER**, then press **1 [ABC]**.

## 5 Press SET to move the cursor into position for the next character.

## 6 Repeat steps 3 through 5 to complete your title.

### To delete a character (ABCD → ABD)

① Use **SEARCH** **◀◀** or **▶▶** to move the cursor to the position of the character you want to delete.

② Press **DELETE**.

### To insert a character (ABCD → AB<sup>T</sup>CD)

① Use **SEARCH** **◀◀** or **▶▶** to move the cursor to the position where you want to insert the character.

② Use **CHARA.** and the jog dial (or **CHAR.** and the character buttons on the remote) to select the new character. The character previously in that position automatically moves to the right.

③ Press **SET** to set the character.

### To insert a space (ABCD → AB\_CD)

① Use **SEARCH** **◀◀** or **▶▶** to move the cursor to the position where you want to insert the space.

② Press **+10 [SPACE]** on the remote.

## 7 Press TITLE to exit the title mode.

If a title consists of more than 12 characters, it will scroll across the display once and then be displayed in abbreviated form (first 12 characters only).

### To undo TITLE

1 Press **□** (STOP **□** on the remote) to display the total tracks and total playing time on the disc.

2 Press **EDIT** repeatedly to display “Undo Title”, then press **ENTER**.

“Undo OK ?” appears in the display.

3 Press **ENTER** again to undo.

To cancel, press **CANCEL** (or **□**).

### After titling

Update the TOC information by using TOC WRITE function or eject the disc to save changes.

# TIMER OPERATIONS

With a commercially available audio timer, it is possible to make recordings and initiate playback automatically at any time.

Make sure that all power cord connections between the timer and amplifier/receiver are properly made.

For details, refer to the instructions of your audio timer. No change in any of the other connections between the recorder and amplifier/receiver, etc., is necessary.

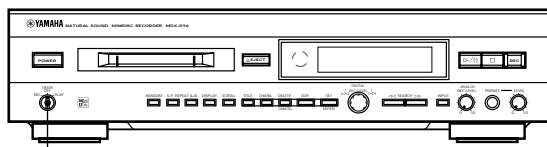

TIMER

## Timer Recording

**1** Turn on the power of each component, then set your tuner to the station you want to record.

**2** Set this unit's recording options.  
Select digital or analog inputs, auto or manual marking, stereo or mono recording and then set the recording level.

**3** Turn down the volume on your amplifier/receiver.  
This has no effect on the recording level.

**4** Set the timer to the times at which you want to start and stop recording.  
We recommend setting the timer to start a few minutes before and stop a few minutes after the actual broadcast to leave some room for later editing.

**5** Set **TIMER** to REC.  
When the preset time arrives, the timer turns on the components (amplifier/receiver, tuner and MD recorder) and the MD recorder starts to record. When the stop time arrives, the timer stops the recording by turning off the components.

### Notes

- When recording to a blank MD, recording starts from the beginning. When recording to a previously recorded MD, recording starts from the end of the last track.
- Set **TIMER** to OFF when not using the timer recording function. If the power is turned on (by pressing **POWER**, plugging in the power cord, etc.) when **TIMER** is set to REC, the MD recorder will start recording automatically.
- When timer recording is performed, the recorded contents are not written to the MD until the the unit is turned on again. When the unit is turned on, "TOC Writing" appears in the display. While this message appears, do not subject the unit to shock or vibration or turn off the power.
- During timer recording, recording is stopped when there is no remaining recording time on the MD.

## Timer Playback

- 1** Turn on the amplifier/receiver and adjust the volume and tone controls.
- 2** Set the input mode selector of your amplifier/receiver to MD.
- 3** Set the timer to the times at which you want to start and stop playback.
- 4** Set **TIMER** to PLAY.

When the preset time arrives, the timer turns on the components (amplifier/receiver and MD recorder) and the MD recorder starts to play. When the stop time arrives, the timer stops the playback by turning off the components.

### Notes

- Playback always starts from the beginning of the MD.
- Set **TIMER** to OFF when not using the timer play function. If the power is turned on (by pressing **POWER**, plugging in the power cord, etc.) when **TIMER** is set to PLAY, the MD recorder will start to play and may cause a sudden output at high volume.

# MD SYSTEM LIMITATIONS

The recording system in your MD recorder is radically different from those used in cassette and DAT decks and is characterized by the limitations described below.

Note, however, that these limitations are inherent to the MD recording system and are not a result of mechanical trouble.

## **“Can’t REC” is displayed before the maximum recording time (60, 74 or 80 minutes) has been reached**

Once 255 tracks have been recorded on one MD, “Can’t REC” is displayed regardless of the total recorded time. More than 255 tracks cannot be recorded on one MD. To continue recording, erase unnecessary tracks, combine tracks to reduce the total number of tracks, or use another recordable MD.

## **“Disc Full” is displayed before the maximum number of tracks (255) have been recorded**

During automatic track marking, fluctuations in emphasis within songs may be interpreted as song intervals, increasing the total number of tracks and causing “Disc Full” to be displayed.

## **The remaining recording time does not increase even after erasing numerous short tracks**

Tracks under 12 seconds in length are not counted and so erasing them may not lead to an increase in the recording time.

## **“TOC Reading” is displayed continuously**

The “TOC Reading” display lasts longer than normal when a brand new (blank) disc is inserted.

## **The total recorded time and the remaining time on the MD do not total to the maximum recording time**

- Recording is done in minimum units of 2 seconds each, no matter how short the material. The contents recorded may thus be shorter than the maximum recording capacity. Disc space may also be further reduced by scratches.
- This unit displays the length of the largest continuous blank area as the remaining time. Therefore, if there are several separate blank spaces, the remaining time will only display a time equivalent to the largest continuous blank space.

If there is a 1 minute blank space and a 2 minute blank space, the remaining time display will be “2” minutes. If you then record 1 minute and 30 seconds of the 2 minute blank, the remaining time display will become “1” minute.

## **Tracks created through editing may exhibit sound dropout during search operations.**

## **Track numbers are not recorded correctly**

Incorrect assignment or recording of track numbers may result when CD tracks are divided into several smaller tracks during digital recording.

## **It is not possible to erase part of a track using the A-B ERASE function**

This unit organizes the audio data in sound groups and clusters. The minimum size of these units varies according to the number of channels being recorded. For a 2 channel (stereo) recording, a single unit may not consist of less than 10 seconds of sound. For one channel (mono) recording, a single unit may not consist of less than 20 seconds of sound.

## **Limitations when recording over an existing track**

- The correct remaining recording time may not be displayed.
- You may find it impossible to record over a track if that track has been recorded over several times already. If this happens, erase the track using the ERASE function.
- The remaining recording time may be shortened out of proportion to the total recorded time.
- Recording over a track to eliminate noise is not recommended since this may shorten the duration of the track.
- You may find it impossible to label a track while recording over another track.

## **The correct recorded/playing time may not be displayed during playback of MDs recorded in monaural.**



# DISPLAY MESSAGES

## **Can't Copy**

Digital recording cannot be performed. (See "COPY PROTECTION (SCMS)" on this page.)

## **Can't Edit**

Edit operations are not possible.

## **Can't Play**

Timer playback is not possible. The loaded disc may be blank, damaged, or an incompatible format.

## **Can't REC**

- Timer recording is not possible. The loaded disc may be protected or there may not be enough blank space remaining on the disc.
- Recording is not possible because there is not enough blank space remaining on the disc.

## **DIGin Unlock**

No digital signal is being input to the selected digital input jack.

## **TMP Over!!**

The temperature of the unit has exceeded the normal operating temperature. Turn off the unit and let it cool down. If the unit is installed in a place with little ventilation (such as a built in bookcase), move the unit to another location with better ventilation.

## **Disc Full**

Recording is not possible because there is no blank space remaining on the disc.

## **Title Full**

Additional characters cannot be input for the current title because the maximum number of characters for a single title (250) has already been input.

## **UTOC W Error**

Error occurred when writing to the UTOC.

## **Not Audio**

The inserted disc is not an audio MD.

## **Tr Protected**

The selected track cannot be edited because it is protected.

## **TOC Full**

The disc area allotted for TOC data has become full and further editing is not possible.

## **UTOC ERR ...**

Problem involving UTOC data.

## **TOC Writing**

The TOC data is being written to the disc. Do not move the unit or pull out the mains lead. If you do, recorded material may not be saved normally.

## **TOC Reading**

The unit is reading the TOC data.

## **Protected**

The record protection on the inserted MD is set to "protect".

## **Playback MD**

The inserted MD is a designed for playback only (you cannot record on this disc).

## **MONITOR OUT**

The monitor out function is active. The audio signal input to the selected input terminals is output from this unit's output terminals.

## **Fade in**

The fade-in function is being performed. Recording is started with a gradual increase in volume reaching the recording level in about 10 seconds.

## **Fade out**

The fade-out function is being performed. The unit is put in the record pause mode after a gradual fade-out to a minimum volume in about 10 seconds.

# COPY PROTECTION (SCMS)

As a digital audio component, this MD recorder conforms with the Serial Copy Management System (SCMS) standards. The Serial Copy Management System restricts copies made by recording digital signals to first-generation copies only. Therefore, an MD recorded through a digital input cannot be used as a source for making another digital recording.

---

## **Care of MDs**

- Do not expose the MD to direct sunlight or heat sources such as hot air ducts, nor leave it in a car parked in direct sunlight as there can be a considerable rise in temperature inside the car.
- Periodically remove dust and debris from the cartridge surface by wiping it with a dry cloth.
- Because the MD itself is housed in a cartridge, you can handle it normally without being concerned about dirt or fingerprints. However, malfunctioning may result if the cartridge itself is dirty or warped.

## **Do not open the shutter on the MD cartridge**

Trying to force the shutter open will damage the shutter.

# TROUBLESHOOTING

If your MD recorder fails to operate normally, check the following table. It lists common operating errors and simple measures which you can take to correct the problem. If it cannot be corrected, or the symptom is not listed, disconnect the recorder's power cord and contact your authorized YAMAHA dealer or service center for help.

Symptom	Cause	Remedy
<b>The unit does not respond to operations.</b>	<ul style="list-style-type: none"> <li>• MD is dirty or damaged.</li> <li>• MD is damaged ("UTOC ERR" appears in the display).</li> </ul>	<ul style="list-style-type: none"> <li>• Replace the current disc with a new one.</li> </ul>
<b>It happens that this unit does not work normally.</b>	<ul style="list-style-type: none"> <li>• There is an influence of strong external noise (lightning, excessive static electricity, etc.) or a misoperation was performed while using this unit.</li> </ul>	<ul style="list-style-type: none"> <li>• Turn the power off and disconnect the AC power from the AC outlet. After about 30 seconds have passed, connect the power and try again.</li> </ul>
<b>Playback is not possible.</b>	<ul style="list-style-type: none"> <li>• Moisture is on the laser pickup.</li> <li>• The power is OFF.</li> <li>• The disc has been loaded incorrectly.</li> <li>• An unrecorded (blank) MD was loaded ("Blank Disc" appears in the display).</li> </ul>	<ul style="list-style-type: none"> <li>• Leave the unit switched ON and wait 20 to 30 minutes for the moisture to evaporate before trying to play a disc.</li> <li>• Press <b>POWER</b> to turn the power on.</li> <li>• Reload the disc with the label side facing up, and the arrow pointing toward the disc insertion slot.</li> <li>• Insert a recorded MD.</li> </ul>
<b>Recording is not possible.</b>	<ul style="list-style-type: none"> <li>• The disc is write protected ("Protected" appears in the display).</li> <li>• A pre-mastered MD is loaded ("Playback MD" appears in the display).</li> <li>• The source is not connected correctly.</li> <li>• The input setting is incorrect.</li> <li>• The recording level is too low.</li> <li>• The digital output level of the digital source is too low.</li> <li>• There is not enough blank space left on the MD.</li> <li>• If the power cord was unplugged or there was a power outage during recording, that recording may be lost.</li> </ul>	<ul style="list-style-type: none"> <li>• Slide the write-protect tab to the closed position.</li> <li>• Load a recordable MD.</li> <li>• Check all connections again.</li> <li>• Press <b>INPUT</b> repeatedly to select the correct input jacks.</li> <li>• Turn <b>REC LEVEL</b> to adjust the recording level.</li> <li>• Set the digital output level of the digital source to "MAX".</li> <li>• Load a recordable MD with fewer recorded tracks, or erase unnecessary tracks from the current MD.</li> <li>• If recording was interrupted, try recording again starting from the beginning.</li> </ul>
<b>The MD cannot be removed when partially inserted.</b>	<ul style="list-style-type: none"> <li>• The carriage lock function has activated.</li> </ul>	<ul style="list-style-type: none"> <li>• Insert the MD completely, then press <b>EJECT</b> to eject it.</li> </ul>
<b>Excessive noise.</b>	<ul style="list-style-type: none"> <li>• The unit is too close to the television or other component.</li> </ul>	<ul style="list-style-type: none"> <li>• Place the unit farther away from the television or other component.</li> </ul>
<b>The remote control does not operate.</b>	<ul style="list-style-type: none"> <li>• The batteries are exhausted.</li> <li>• The remote control transmitter is operated from an incorrect distance or angle.</li> <li>• The remote control sensor is located in strong direct light.</li> </ul>	<ul style="list-style-type: none"> <li>• Replace the batteries.</li> <li>• Operate the remote from less than 6 meters and within 30° on either side of the sensor.</li> <li>• Place the unit away from the strong light.</li> </ul>

# SPECIFICATIONS

## Digital audio system

---

### System

MiniDisc digital audio system

### Disc

Mini Disc

### Recording method

Magnetic field variation overwrite

### Reading method

Non-contact optical pickup (using semiconductor laser)

### Laser

Semiconductor laser

### Laser Diode Properties

Material: GaAlAs

Wavelength: 785 nm

Pulse time:

Read mode ... 0.6 mW Continuous

Write mode ... Accessible Emission Level 2.6 mW

0.5S

min cycle 1.5S

Repetition

### Record/Playback Time

Max. 80 minutes (using MDW-80 disc)

80 minutes (stereo)

160 minutes (mono)

### Revolutions

Approx. 400 – 900 rpm (CLV)

### Error Correction

ACIRC (Advanced Cross Interleave Reed-solomon Code)

### Sampling Frequency

44.1 kHz (32 kHz and 48 kHz signals converted to

44.1 kHz for recording)

### Coding

ATRAC (Adaptive TRansform Acoustic Coding)

### Modulation system

EFM (Eight-to-Fourteen Modulation)

### Number of channels

2 (stereo) or 1 (monaural, for extended recording)

### Frequency Response

5 – 20,000 Hz  $\pm 0.5$  dB

### Signal-to-Noise Ratio

More than 99 dB during playback

### Wow and Flutter

Below measurable limit

## Inputs

---

### LINE IN (REC)

Type: pin jack

Sensitivity (50 k-ohms): 300 mV

### DIGITAL IN (OPTICAL) (2)

Type: square optical connector jack

## Outputs

---

### LINE OUT (REC)

Type: pin jack

Standard output level (1 kHz, 0 dB):  $2.0 \pm 0.5$  Vrms

### DIGITAL OUT (OPTICAL)

Type: square optical connector jack

### PHONES

Standard output level

(Input 150 ohms shorted,  $-20$  dB):  $300 \pm 60$  mV

## General

---

### Power Supplies

230 V, 50 Hz (U.K. and Europe models)

110/120/220/240 V, 50/60 Hz (General model)

240 V, 50 Hz (Australia model)

### Power Consumption

18 W

### Dimensions (W x H x D)

435 x 96 x 288 mm

### Weight

4.0 kg

### Accessories

Remote control x1

Audio connecting cords x2

Optical fiber cable x1

Batteries (size AA, R6, UM-3) x2

Specifications subject to change without notice.



---

**YAMAHA ELECTRONICS CORPORATION, USA** 6660 ORANGETHORPE AVE., BUENA PARK, CALIF. 90620, U.S.A.  
**YAMAHA CANADA MUSIC LTD.** 135 MILNER AVE., SCARBOROUGH, ONTARIO M1S 3R1, CANADA  
**YAMAHA ELECTRONIK EUROPA G.m.b.H.** SIEMENSSTR. 22-34, 25462 RELLINGEN, BEI HAMBURG, F.R. OF GERMANY  
**YAMAHA ELECTRONIQUE FRANCE S.A.** RUE AMBROISE CROIZAT BP70 CROISSY-BEAUBOURG 77312 MARNE-LA-VALLEE CEDEX02, FRANCE  
**YAMAHA ELECTRONICS (UK) LTD.** YAMAHA HOUSE, 200 RICKMANSWORTH ROAD WATFORD, HERTS WD1 7JS, ENGLAND  
**YAMAHA SCANDINAVIA A.B.** J A WETTERGRENS GATA 1, BOX 30053, 400 43 VASTRA FRÖLUNDA, SWEDEN  
**YAMAHA MUSIC AUSTRALIA PTY, LTD.** 17-33 MARKET ST., SOUTH MELBOURNE, 3205 VIC., AUSTRALIA

**YAMAHA CORPORATION**

Printed in Malaysia © V600770